

IX. *On Molecular Influences.*—PART I. *Transmission of Heat through Organic Structures.* By JOHN TYNDALL, F.R.S.

Received October 20, 1852,—Read January 6, 1853.

THE various solid substances which are met with in nature allow themselves to be classed under three general heads:—Amorphous, Crystalline and Organized. In amorphous bodies the component particles are confusedly mingled, without any regard to symmetry of arrangement. In crystalline bodies, on the contrary, the particles are symmetrically arranged; the mass appears as if built up according to certain architectural rules, and the result is an exterior form whose angular dimensions are perfectly constant for all crystals of the same class. Organized bodies, as the name implies, are bodies endowed with, or composed of, organs formed with reference to the special functions they are intended to discharge, and in the construction of which a molecular architecture of a very composite order comes into play. The granules, cells, glands, tubes, &c. of animal and vegetable tissues are all, of course, the visible products of this architecture. Crystalline bodies appear to bridge the chasm which separates the amorphous from the organized. Like the former, they are devoid of the powers of assimilation and reproduction—like the latter, their particles are arranged according to rule; as if nature, in the case of crystals, had made her first structural effort. The student of nature has ever looked upon these molecular combinations with an inquiring eye, and, perhaps, at no age of the world more than at present. The molecular peculiarities of any substance declare themselves by the manner in which a force is modified in its passage through the substance. The polarization and bifurcation of a luminous ray in doubly refracting media is an old example of molecular action; and the rotation of the plane of polarization, observed by Professor FARADAY, may be the result of a mechanical change of the medium, effected by the current or the magnet. SENARMONT'S\* and KNOBLAUCH'S† experiments demonstrate the influence of crystalline structure upon the transmission of heat; and the magnecrystallic discoveries of PLÜCKER and FARADAY receive, I believe, their true explanation by reference, simply, to the modification of the magnetic and diamagnetic forces which peculiarity of aggregation induces. Matter, in this aspect, may be regarded as a kind of organ through which force addresses our senses; if the organ be changed, it is reasonable to infer that the utterance will be correspondingly modified,—an inference which is abundantly corroborated by experiment. Thus, mechanical pressure will polarize a ray, and the same may be

\* *Annales de Chimie et de Physique*, vols. xxi. xxii. xxiii.

† *POGGENDORFF'S Annalen*, vol. lxxxv. p. 169.

applied with success to produce all the phenomena of magnecrystallic action. The anomalies which owe their origin to peculiarities of aggregation are indeed manifold, and constitute one of the most important subjects of study which can engage the attention of the natural philosopher.

Organic structures furnish an ample field for inquiries into molecular action. For here, as before remarked, nature, to attain her special ends, has arranged her materials in a particular manner. To ascertain what effect the molecular structure of wood has upon the transmission of heat through it, constitutes the object of the first part of this investigation.

Upwards of twenty years ago MM. DE LA RIVE and DECANDOLLE instituted an inquiry into the conductive power of wood\*, and in the case of five specimens examined established the fact of the feeble conductivity of the substance, and also that the velocity of transmission was greater along the fibre than across it. The manner of experiment was that usually adopted in inquiries of this nature, and applied to metals by M. DEPRETZ†. A bar of the substance was taken, one end of which was brought into contact with a source of heat and allowed to remain so until a stationary temperature was assumed. The temperatures attained by the bar, at various distances from its heated end, were ascertained by means of thermometers fitting into cavities made to receive them; from these data, with the aid of a well-known formula, the conductivity of the wood was determined. Since the publication of their results by the distinguished men above mentioned, nothing, so far as I am aware of, has been done in connexion with this subject.

The mode of experiment here indicated is, however, by no means sufficiently delicate for an inquiry like the present. Some other mode must therefore be devised. I will not trouble the reader with a rehearsal of the long series of trials which have led to the construction of the instrument employed in these researches, but will proceed at once to the description of it.

QQ' RR', fig. 1, is an oblong piece of mahogany 3·4 inches long, 1·8 inch wide and 0·5 of an inch deep. A is a bar of antimony, B is a bar of bismuth, each measuring 1·5 inch in length, 0·07 of an inch in breadth and 0·3 of an inch in depth. The ends of the two bars are kept in close contact by the ivory jaws I, I', and the other ends are let into a second piece of ivory *i*, in which they are firmly fixed. Soldered to these ends are two pieces of platinum wire which proceed to the little ivory cups MM', enter through the sides of the cups and communicate with a drop of mercury placed in the interior. The wood is cut away, so that the bars A and B are sunk to a depth which places their upper surfaces a little below the general level of the slab of mahogany. The ivory jaws I, I' are sunk similarly. Two small projections are observed in the figure jutting from I, I'; across from one projection to the other a fine membrane is drawn, thus enclosing a little chamber *m*, in front of the wedge-like end of the bismuth and antimony junction; the chamber has an ivory bottom. S is a wooden

\* Mém. de la Soc. de Genève, vol. iv. p. 70.

† Annales de Chim. et de Phys. December 1827.

slider, which can be moved smoothly back and forward along a bevelled groove, by means of the lever *L*. This lever turns on a pivot near *Q*, and fits into a horizontal slit in the slider, to which it is attached by the pin *p'* passing through both; in the lever an oblong aperture is cut through which *p'* passes, and in which it has a certain amount of lateral play, so as to enable it to push the slider forward in a straight line. A small chamber, *m'*, is cut out at the end of the slider, and across, from projection

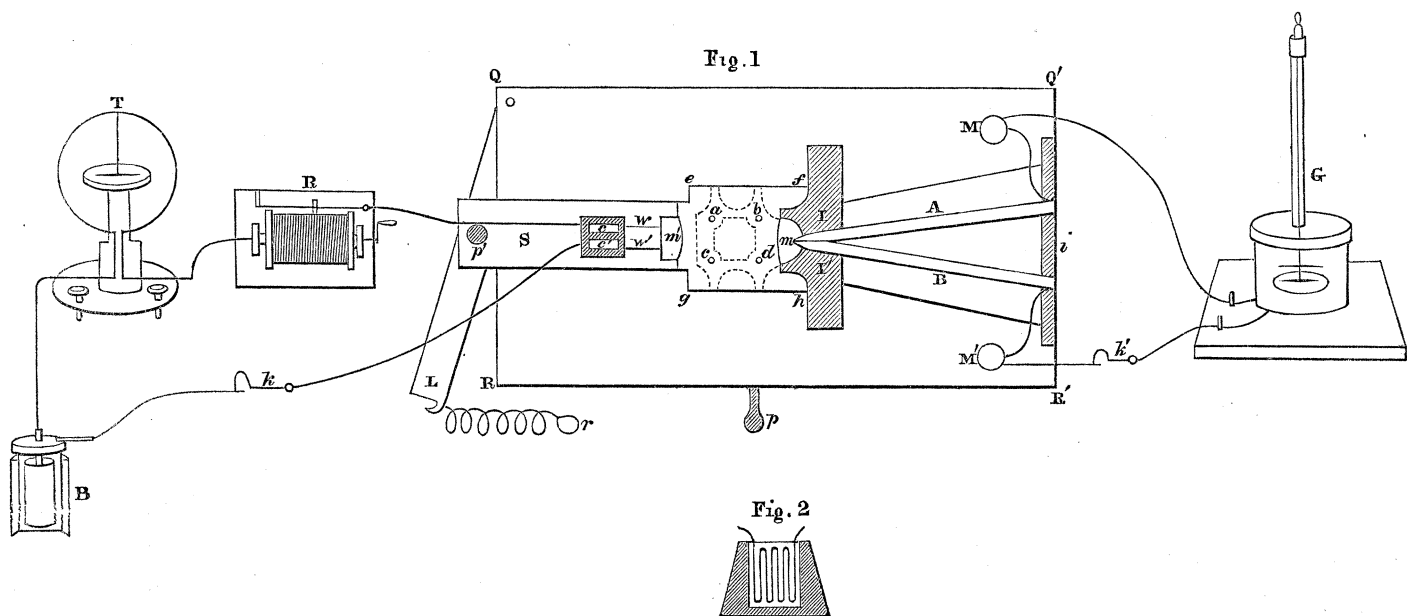

to projection, a thin membrane is stretched; a chamber is thus formed bounded on three sides and the bottom by wood, and in front by the membrane. A thin platinum wire, bent up and down several times, so as to form a kind of micrometer grating, is laid against the back of the chamber and imbedded in the end of the slider by the stroke of a hammer; the end in which the wire is imbedded is then filed down until about half the latter is removed, and the whole is reduced to a uniform flat surface. Against the common surface of the slider and wire an extremely thin plate of mica is glued, sufficient, simply, to interrupt all contact between the bent wire and a quantity of mercury which the chamber *m'* is destined to contain: the ends *w w'* of the bent wire proceed to two small cisterns, *c c'*, hollowed out in a slab of ivory; they enter through the substance into the cisterns, and come thus into contact with mercury which fills the latter. The end of the slider and its bent wire are shown in fig. 2. The rectangular space *efgh*, fig. 1, is cut quite through the slab of mahogany, and a brass plate is screwed to the latter underneath; from this plate (which, for reasons to be explained presently, is cut away as shown by the dotted lines in the figure) four conical ivory points, *abcd*, project upwards; though appearing to be upon the same plane as the upper surfaces of the bismuth and antimony bars, the points are in reality 0.3 of an inch below the said surfaces.

The body to be examined is reduced to the shape of a cube, and is placed, by means of a pair of pliers, upon the four supports *abcd*; the slider *S* is then drawn up against the cube, and the latter becomes firmly clasped between the projections of the piece of ivory *II'*, on the one side, and those of the slider *S*, on the other. The chambers *m m'* being filled with mercury, the membrane in front of each is pressed gently against the cube by the interior fluid mass, and in this way perfect contact is secured. In fact the principle here applied is the same as that made use of by FOURIER\* in his thermometer of contact, although both instruments have nothing else in common.

The problem which requires solution is the following:—It is required to apply a source of heat of a strictly measurable character, and always readily attainable, to that face of the cube which is in contact with the membrane at the end of the slider, and to determine the quantity of this heat which crosses the cube to the opposite face in a minute of time. For the solution of this problem two things are required:—first, the source of heat to be applied to the left hand of the face of the cube, and secondly, a means of measuring the amount which has made its appearance at the opposite face at the expiration of a minute.

To obtain a source of heat of the nature described the following method was adopted:—*B* is a small galvanic battery, from the negative pole of which a current proceeds to the galvanometer of tangents *T*; passes round the ring of the instrument, deflecting, in its passage, the magnetic needle which hangs in the centre of the ring. The strength of the current is, as is known, proportional to the tangent of the angle of permanent deflection. From *T* the current proceeds to the rheostat *R*; this instrument consists of a cylinder of serpentine stone, round which a German silver wire is coiled spirally; by turning the handle of the instrument any required quantity of this powerfully resisting wire is thrown into the circuit, the current being thus regulated at pleasure. The sole use of these two last instruments in the present series of experiments is to keep the current perfectly constant from day to day. From the rheostat the current proceeds to the cistern *c*, thence through the bent wire, and back to the cistern *c'*, from which it proceeds to the other pole of the battery.

The bent wire, during the passage of the current, becomes heated; this heat is transmitted through the mercury in the chamber *m'* to the membrane in front of the chamber; this membrane becomes the proximate source of heat which is applied to the left-hand face of the cube. The quantity transmitted from this source, through the mass of the cube, to the opposite face, in any given time, will, of course, depend on the conductivity of the latter, and its amount may be estimated from the deflection which it is able to produce upon the needle of a galvanometer connected with the bismuth and antimony pair. *G* is a galvanometer used for this purpose; from it proceed wires to the mercury cups *M M'*, which, as before remarked, are connected by platinum wires with *A* and *B*. The galvanometer is a carefully constructed and delicate instrument from the workshop of that skilful mechanic, KLEINER, in Berlin.

\* *Annales de Chimie et de Physique*, March 1828.

The sole use of the mercury in the chambers  $m$  and  $m'$  is to secure good and equable contact; when the chambers are filled with pure mercury, and this is allowed to remain in them throughout an entire series of experiments, it is certain that the conditions of contact are perfectly constant, and thus the most fruitful source of doubt and error is effectually excluded. In rough experiments the chambers might be dispensed with, and the bent wire itself might be brought into contact with one face of the cube, while the other face might immediately press against the bismuth and antimony. The result however of many hundreds of experiments made with the instrument in this state, has been to prove the impossibility of preserving the conditions of experiment constant, and to compel me to devise some means of avoiding the irregularities which exhibited themselves. The instrument just described meets the requirements of the case; care is necessary in the use of it, but when care is taken, an accuracy is attainable by it which, I believe, has been hitherto unequalled.

The action of mercury upon bismuth, as a solvent, is well known; an amalgam is speedily formed where the two metals come into contact. To preserve our thermo-electric couple from this action, their ends are protected by a sheathing of the same membrane as that used in front of the chambers  $m m'$ .

Previous to the cube being placed between the two membranes, the latter, by virtue of the fluid masses behind them, bulge out a little, thus forming a pair of soft and slightly convex cushions. When the cube is placed upon its supports and the slider is brought up against it, both cushions are pressed flat, and thus perfect contact is secured. The surface of the cube is larger than the surface of the membrane in contact with it\*; and thus the former is always firmly caught between the opposed rigid projections, the slider being held fast in this position by means of the spring  $r$ , which is then attached to the pin  $p$ . The exact manner of experiment is as follows:— Having first seen that the needle of the galvanometer points to zero, when the thermo-circuit is complete, the latter is interrupted by means of the break-circuit key  $k'$ . At a certain moment, marked by the seconds-hand of a watch, the voltaic circuit is closed by the key  $k$ , and the current is permitted to circulate for sixty seconds; at the sixtieth second the voltaic circuit is broken by the left hand at  $k$ , while almost at the same instant the thermo-circuit is closed by the right hand at  $k'$ . The needle of the galvanometer is instantly deflected, and the limit of the first impulsion is noted; the amount of this impulsion depends, of course, upon the quantity of heat which has reached the bismuth and antimony junction through the mass of the cube during the time of action, and consequently upon the conductive power of the latter. The limit of the first impulsion being noted, the cube is instantly removed, and the instrument is allowed to cool until the needle of the galvanometer returns to zero. To expedite the cooling, the metallic surfaces of A and B are to a great extent exposed; the wood is cut away all round them, and from the space between them; they do not rest upon the wood, their sole points of support being the ivory  $i$  at one end and the

\* The edge of each cube measured 0·3 of an inch.

jaws II' at the other. The cube, as before explained, does not touch the brass plate underneath it, but is supported on its four conical points, and the plate which bears these is itself as much as possible cut away to permit of a free circulation of air through the space *efgh*. Time is a precious commodity to the experimenter, and by the means described the cooling is hastened and the experiments can succeed each other more quickly. To hasten the cooling further I made use of a pair of small bellows during the first minute after the removal of each cube, and, afterwards, a plate of thin glass was placed over the junction, but not in contact with it. On the glass two drops of ether were suffered to fall from a pipette; its evaporation caused a refrigeration of the air underneath, which, in virtue of its increased density, sank and diffused itself around the place of junction. In this way the temperature at the junction was brought a little lower than that of the surrounding air; the needle of the galvanometer being thus brought back, not only to zero, but to a certain point at the other side of it; at this point the glass was removed and a new cube was introduced; the thermo-circuit was permitted to remain closed until the needle descended to zero, which it slowly did, when the cause of local cooling was removed; the thermo-circuit was then broken at *k'*, and things stood as at the commencement of the former experiment. The voltaic circuit was once more closed, the current permitted to circulate sixty seconds, then interrupted by the left hand, the thermo-circuit being closed at the same moment with the right, and the first impulsion measured as before.

When however these artificial means of cooling are adopted great care is necessary. We must not use the bellows in some experiments and neglect the use of it in others; and if the ether be applied once, it must be applied throughout the entire series of experiments. It must continue to act for the same time, and the same quantity should be applied in all cases. Of course such precautions are only necessary when great accuracy is required, but here they are absolutely necessary. Judging from the description, the mode of experiment may appear complicated, but in reality it is not so. A single experimenter has the most complete command over the entire arrangement. The wires from the small galvanic battery (four of BUNSEN'S cells) remain undisturbed from day to day; all that is to be done is to connect the battery with them, and every thing is ready for experiment.

There are in wood three lines at right angles to each other, which the mere inspection of the substance enables us to fix upon as the necessary resultants of molecular action: the first line is parallel to the fibre; the second is perpendicular to the fibre, and to the ligneous layers which indicate the annual growth of the tree; while the third is perpendicular to the fibre and parallel, or rather tangent to the layers. From each of a number of trees a cube was cut, so that every two opposite faces were parallel to one of the above lines. Thus, two faces were parallel to the ligneous layers, two perpendicular to them, while the remaining two were perpendicular to the fibre. It was proposed to examine the velocity of calorific transmission through the

mass in these three directions. It may be remarked that the cubes were fair average specimens of the woods, and were in all cases well-seasoned and dry.

The cube was first placed upon its four supports *abcd*, so that the line of flux from *m'* to *m* was parallel to the fibre, and the deflection produced by the heat transmitted in sixty seconds was observed. The position of the cube was then changed so that its fibre stood vertical, the line of flux from *m'* to *m* being perpendicular to the fibre and parallel to the ligneous layers; the deflection produced by a minute's action in this case was also determined. Finally, the cube was turned 90° round, its fibre being still vertical, so that the line of flux was perpendicular to both fibre and layers, and the consequent deflection was observed. In the comparison of these two latter directions the chief delicacy of manipulation is necessary. It requires but a rough experiment to demonstrate the superior velocity of propagation along the fibre, but the velocities in all directions perpendicular to the fibre are so nearly equal that it is only by the greatest care and, in the majority of cases, by numerous experiments, that a differential action can be securely established.

The following table contains the results of the inquiry; it will explain itself.

TABLE I.—Strength of Current used to heat the bent Wire, as measured by the tangent galvanometer:—constantly 35°. Deflections, the line of flux being of:—

Description of wood.	I. Parallel to fibre of wood.	II. Perpendicular to fibre and parallel to lig- neous layers.	III. Perpendicular to fibre and to ligneous layers.	Description of wood.	I. Parallel to fibre of wood.	II. Perpendicular to fibre and parallel to lig- neous layers.	III. Perpendicular to fibre and to ligneous layers.
American Birch.....	35	9	11			10.5	11.0
Oak.....	33	9.5	11			9.5	11.0
						10.5	9.5
						8.0	10.5
		8.0	11.0	Black Ebony .....	32	Mean 9.5	Mean 10.5
		9.0	10.0				
		9.7	11.2	Bird's-eye Maple ...	31	11	12
Beech .....	33	Mean 8.8	Mean 10.8				
						9.8	12.0
						10.0	11.0
						11.5	12.0
						11.0	13.5
Coromandel-wood. An exceedingly hard wood from Ceylon	33	Mean 9.8	Mean 12.3	Lance-wood .....	31	Mean 10.6	Mean 12.1
		10.2	12.2			8.0	10.0
		10.2	12.0			8.0	10.0
		9.5	12.0	Zebra-wood. The produce of the Brazils .....	31	Mean 8.2	Mean 10.0
		9.5	13.0				
Quebec Pine .....	33	10	11			8.5	10.0
						9.8	12.3
						10.0	11.7
Beef-wood. A red-coloured wood from New South Wales .....	33	Mean 10.0	Mean 11.4			10.0	12.0
						10.0	12.0
				Box-wood .....	31	Mean 9.9	Mean 12.0

TABLE I. (Continued.)

Description of wood.	I. Parallel to fibre of wood.	II. Perpendicular to fibre and parallel to lig- neous layers.	III. Perpendicular to fibre and to ligneous layers.	Description of wood.	I. Parallel to fibre of wood.	II. Perpendicular to fibre and parallel to lig- neous layers.	III. Perpendicular to fibre and to ligneous layers.
		11·5 11·5 10·5 11·0	12·5 12·0 12·0 12·0	King-wood. Called also violet- wood, from the Bra- zils .....	30	10·0 10·5 10·5	12·0 12·0 11·0
Tamarind-wood .....	31	Mean 11·1	Mean 12·1	Bladder-nut-wood ...	29	10·0	12·0
		10·0 9·5 10·0 10·0	12·0 13·0 13·0 11·5	Larch .....	29	10·0	11·0
Teak-wood .....	31	Mean 9·9	Mean 12·4			11·0 10·0 11·2 12·0	14·0 12·0 14·0 12·0
		10·5 10·0 10·0 11·0	12·0 13·5 13·0 12·0	Princes-wood. From Jamaica .....	29	Mean 11·1	Mean 13·1
Rose-wood .....	31	Mean 10·4	Mean 12·6			11·5 11·5 12·5 11·2	13·0 12·0 12·8 12·5
		10·5 10·5	13·0 12·0	Green Heart. From Jamaica .....	29	Mean 11·4	Mean 12·6
Mazatlan-wood .....	30	Mean 10·5	Mean 12·5	Walnut .....	28	11·0	13·0
		12·5 11·0 12·0 12·0	12·5 12·0 12·7 12·0	Drooping Ash .....	28	11·0	12·0
Satin-wood. From St. Domingo...	30	Mean 11·9	Mean 12·3	Botany Bay Oak. Does not belong to the same genus as the European.....	28	10·0 10·0 10·5 9·0	13·0 12·6 12·2 12·0
		9·0 9·0 10·0 9·0	11·0 10·5 11·0 11·5			12·0 12·5 12·0 11·2	13·0 14·0 13·5 14·0
Braziletto. From Jamaica .....	30	Mean 9·2	Mean 11·0	Cocoa-wood. From the West In- dies.....	28	Mean 11·9	Mean 13·6
		10·0 10·0 10·0	10·5 11·5 11·0			11·3 11·2 10·5 10·0	12·0 12·5 11·8 11·0
Locust-wood. From North America.	30	Mean 10·0	Mean 11·0	Madagascar Red- wood .....	28	Mean 10·7	Mean 11·8
		11·0 10·0 10·0	11·0 11·0 11·5			11·0 10·5 9·5 9·0	12·0 12·5 11·5 11·0
Ruby-wood. From Calcutta .....	30	Mean 10·3	Mean 11·2	Sandal-wood. From Malabar .....	28	Mean 10·0	Mean 11·7
		11·0 10·5 10·5	12·0 12·0 11·0				
Peruvian-wood .....	30	Mean 10·7	Mean 11·7				



TABLE I. (Continued.)

Description of wood.	I. Parallel to fibre of wood.	II. Perpendicular to fibre and parallel to lig- neous layers.	III. Perpendicular to fibre and to ligneous layers.	Description of wood.	I. Parallel to fibre of wood.	II. Perpendicular to fibre and parallel to lig- neous layers.	III. Perpendicular to fibre and to ligneous layers.
Tulip-wood. From Brazil .....	28	11·0	11·5	Iron-wood. Sp. gr. 1·426 .....	26	9·5	12·5
		11·0	12·5			9·5	12·0
		11·0	12·5			10·2	13·0
		11·0	12·0			10·5	12·0
		Mean 11·0	Mean 12·1			Mean 10·2	Mean 12·4
Camphor-wood. From China .....	28	9·0	10·0	Chestnut.....	26	10·2	12·0
		9·0	10·0			10·0	11·0
		8·0	10·0				
		Mean 8·6	Mean 10·0			Mean 10·1	Mean 11·5
Olive-wood. From Leghorn .....	28	10·0	14·0	Sycamore .....	26	10·2	12·5
		11·0	12·0			11·0	12·0
		10·5	13·0				
		Mean 10·5	Mean 13·2			Mean 10·6	Mean 12·2
Gaffe Deal.....	27	10	11	Spruce Fir .....	25	11·8	12·5
Ash.....	27	9·5	11·5	Honduras Mahogany	25	9·0	10·0
Green Ebony. From Jamaica .....	27	11·0	12·5	Brazil-wood. A red dye-wood, called also Per- nambuco.....	25	12·0	13·0
		11·0	12·0			13·0	14·5
		9·0	13·0			11·5	13·0
		11·0	11·5			11·2	14·0
		Mean 10·5	Mean 12·2			Mean 11·9	Mean 13·9
Black Oak .....	27	8·0	9·0	Yew .....	24	11·0	12·0
		7·0	10·0	Elm.....	24	10·0	11·5
		8·0	10·0	Plane-tree .....	24	10·0	12·0
		8·0	9·0	Portugal Laurel.....	24	10·0	11·5
		Mean 8·0	Mean 9·4				
Apple-tree .....	26	10	12·5	Bullet-wood. From the Virgin Isles, West Indies	24	10·0	12·0
Cam-wood. An African dye-wood	26	13·0	15·0			10·5	12·0
		13·0	15·0			9·5	11·0
		14·0	15·0				
		13·5	15·0				
		Mean 13·4	Mean 15·0	Spanish Mahogany	23	11·5	12·5
				Scotch Fir .....	22	10·0	12·0
				Laurel.....	22	12·0	15·0

To enable the eye to detect, at once, the law of action established by the experiments, we will present the results in a more condensed form.

## Deflections.

Description of wood.	I. Parallel to fibre.	II. Perpendi- cular to fibre and parallel to ligneous layers.	III. Perpendi- cular to fibre and to ligneous layers.	Description of wood.	I. Parallel to fibre.	II. Perpendi- cular to fibre and parallel to ligneous layers.	III. Perpendi- cular to fibre and to ligneous layers.
1 American Birch .....	35°	9°0	11°0	28 Botany Bay Oak .....	28°	9°9	12°4
2 Oak .....	34	9·5	11·0	29 Cocoa-wood .....	28	11·9	13·6
3 Beech .....	33	8·8	10·8	30 Madagascar Red-wood .....	28	10·7	11·3
4 Coromandel-wood.....	33	9·8	12·3	31 Sandal-wood .....	28	10·0	11·7
5 Quebec Pine .....	33	10·0	11·0	32 Tulip-wood .....	28	11·0	12·1
6 Beef-wood .....	33	10·0	11·4	33 Camphor-wood .....	28	8·6	10·0
7 Black Ebony.....	32	9·5	10·5	34 Olive-tree .....	28	10·5	13·2
8 Bird's-Eye Maple .....	31	11·0	12·0	35 Gaffle-Deal .....	27	10·0	11·0
9 Lance-wood .....	31	10·6	12·1	36 Ash .....	27	9·5	11·5
10 Zebra-wood .....	31	8·2	10·0	37 Green Ebony .....	27	10·5	12·2
11 Box-wood .....	31	9·9	12·0	38 Black Oak.....	27	8·0	9·4
12 Tamarind-wood.....	31	11·1	12·1	39 Apple-tree.....	26	10·0	12·5
13 Teak-wood .....	31	9·9	12·4	40 Cam-wood.....	26	13·4	15·0
14 Rose-wood.....	31	10·4	12·6	41 Iron-wood .....	26	10·2	12·4
15 Mazatlan-wood .....	30	10·5	12·5	42 Chestnut .....	26	10·1	11·5
16 Satin-wood .....	30	11·9	12·3	43 Sycamore .....	26	10·6	12·2
17 Braziletto .....	30	9·2	11·0	44 Spruce Fir.....	25	11·8	12·5
18 Locust-wood .....	30	10·0	11·0	45 Honduras Mahogany .....	25	9·0	10·0
19 Ruby-wood .....	30	10·3	11·2	46 Brazil-wood .....	25	11·9	13·9
20 Peruvian-wood .....	30	10·7	11·7	47 Yew .....	24	11·0	12·0
21 King-wood .....	30	10·3	11·7	48 Elm .....	24	10·0	11·5
22 Bladder-nut-wood.....	29	10·0	12·0	49 Plane-tree .....	24	10·0	12·0
23 Larch.....	29	10·0	11·0	50 Portugal Laurel .....	24	10·0	11·5
24 Princes-wood.....	29	11·1	13·1	51 Bullet-wood .....	24	10·0	11·7
25 Green-heart .....	29	11·4	12·6	52 Spanish Mahogany .....	23	11·5	12·5
26 Walnut .....	28	11·0	13·0	53 Scotch Fir.....	22	10·0	12·0
27 Drooping Ash .....	28	11·0	12·0	54 Laurel .....	22	12·0	15·0

The above table furnishes us with the fullest corroboration of the result arrived at by DE LA RIVE and DECANDOLLE, regarding the superior conductivity of the wood in the direction of the fibre. Evidence is also afforded as to how little mere density affects the velocity of transmission. There appears to be neither law nor general rule here. American Birch, a comparatively light wood, possesses undoubtedly a higher transmissive power than any other in the list—a result which has been established by numerous experiments, although but one appears cited in the table. Iron-wood, on the contrary, with a specific gravity of 1·426, stands low. Again, Oak and Coromandel-wood,—the latter so hard and dense that it is used for sharp war-instruments by savage tribes,—stand near the head of the list, while Scotch Fir and other light woods stand low.

We further find that the lateral conductivity bears no definite ratio to the longitudinal conductivity. Indeed the tendency appears to be that those woods which possess the lowest power of transmission, along the fibre, possess the highest power

across it. But here the exceptions are so numerous that we have no warranty for a general conclusion.

But the most remarkable result of the experiments remains yet to be stated. If we cast our eyes along the second and third columns of the tabular summary, we shall find that in every instance the velocity of propagation is greatest in a direction perpendicular to the ligneous layers. This result is, of course, wholly independent of the specific heat of the wood, inasmuch as it is two directions through the self-same cube which are here compared with each other. The law of molecular action, as regards the transmission of heat through wood, may therefore be expressed as follows:—

*At all the points not situate in the centre of the tree, wood possesses three unequal axes of calorific conduction, which are at right angles to each other. The first, and principal axis, is parallel to the fibre of the wood; the second, and intermediate axis, is perpendicular to the fibre and to the ligneous layers; while the third and least axis is perpendicular to the fibre and parallel to the layers.*

The researches of SAVART on the sonorous vibrations of wood naturally suggest themselves here; for, doubtless, the same molecular structure which imparts to this substance the peculiar elastic properties discovered by SAVART, must be regarded as the cause of the differential action established above. SAVART\* took bars of equal size, and in different directions, from a mass of wood; determining their resistance to flexure from the number of vibrations carried out by each in a certain time, he found that wood possessed three axes of elasticity. *These axes coincide with the axes of calorific conduction established by the foregoing experiments.* The axis of greatest elasticity coincides with that of highest conductive capacity, and the axis of least elasticity with that of lowest conductive capacity.

A few exact experiments made with a view to ascertain the influence of molecular structure upon the cleavage of wood would have formed an interesting addition to this communication; fortunately, however, the mere sense of touch, to fingers accustomed to seek for the cleavages of crystals, affords sufficient evidence here. If a piece of wood be taken, on which the rings which mark the growth of the tree plainly appear, and a penknife or a chisel be laid across the rings, it will be found that the pressure necessary to cleave the wood is less in this than in any other direction. The cohesion in the direction parallel to the layers and perpendicular to the fibre is therefore a minimum. In the same way, it will be found that of all lines perpendicular to the fibre the line of greatest cohesion is perpendicular to the ligneous layers; while the cohesion in the direction of the fibre is far greater than along either of the lines just referred to. Hence—

*Wood possesses three axes of cohesion which coincide with the axes of calorific conduction—the greatest with the greatest, and the least with the least.*

It would have also added interest to the inquiry to have examined the permeability

\* TAYLOR'S Scientific Memoirs, vol. i. p. 139.

of wood to fluids in various directions. Here, again, however, the experimental knowledge already amassed by housewives and cask-makers comes to our aid. It is well known that fluids would ooze with facility through a stave cut perpendicular to the fibre; a wooden plate, for instance, cut perpendicular to the axis of a tree would be totally unfit for the bottom of a vessel destined to hold spirits, water, or brine. Further precautions, however, must be taken in choosing staves for casks. If the surface of the stave be parallel to the ligneous layers, the liquid, though with greater difficulty than in the case just mentioned, will still make its way through. The stave must be cut perpendicular to the layers; for, in crossing such a stave, the resistance offered to the passage of the fluid is a maximum. Hence—

*Wood possesses three axes of fluid permeability which coincide with those of calorific conduction,—the greatest with the greatest, and the least with the least.*

To sum up:—In this single substance we have pointed out the existence of three new systems of axis; the axes of calorific conduction, of cohesion, and of fluid permeability; all of which coincide with a fourth system of axes of elasticity discovered by SAVART. The experiments also furnish an illustration of the theory of Professor STOKES, who proves that the flux of heat through any body may be referred to three rectangular axes, which he calls the thermic axes of the body\*.

---

MM. DE LA RIVE and DECANDOLLE have remarked upon the influence which its feeble conducting power in a lateral direction must exert in preserving within a tree the warmth which it acquires from the soil. In virtue of this property a tree is able to resist sudden changes of temperature which would probably be prejudicial to it; it resists alike the sudden abstraction of heat from within and the sudden accession of it from without. But nature has gone further, and clothes the tree with a sheathing of worse-conducting material than the wood itself, even in its worst direction. The following are the deflections obtained by submitting a number of cubes of bark of the same size as the cubes of wood to the same conditions of experiment:—

	Deflection.	Corresponding deflection produced by the wood.
Beech-tree Bark . . . . .	7 <sup>o</sup>	10·8
Oak-tree Bark . . . . .	7	11·0
Elm-tree Bark . . . . .	7	11·5
Pine-tree Bark . . . . .	7	12·0

The direction of transmission, in these cases, was from the interior surface of the bark outwards.

The average deflection produced by a cube of wood, when the flux is lateral, may be taken at

12°;

\* Cambridge and Dublin Mathematical Journal, November 1851.

a cube of rock-crystal (pure silica) of the same size produces a deflection of 90°.

This single experiment is sufficient to show how different must be the meteorological effects of these two substances, when they exist in sufficient quantity to exercise an influence upon climate. Among the more prominent influences here, HUMBOLDT mentions the nature of the soil and of vegetation. The general influence of an arid and exposed soil has been long known, but the part played by this substance, silica, has hitherto had no particular importance attached to it. Were gypsum, however, instead of silica, the prevalent mineral in Sahara, a very different state of things from the present would assuredly exist. A cube of the latter substance examined in the usual manner produces a deflection of

19°

only. It is scarcely superior to wood, while there is the strongest experimental grounds for the belief that silica *possesses a higher conductive power than some of the metals*. These grounds shall be adduced in a future paper.

Let us consider, for a moment, the process which takes place from sunrise to the hour of maximum temperature in a region overspread with forests, and compare it with that which must take place in the African Desert. In the former case, the heat slowly and with difficulty penetrates the masses of wood and leaves on which it falls, and after the point of maximum temperature is passed, the yielding up of the heat acquired is proportionately slow. In the desert, however, the mass of silica exposed to the sun becomes burning hot as the hour of maximum temperature approaches; but, after this is passed, the heat is yielded up with proportionate facility. Hence a maximum and minimum thermometer must, in the latter case, mark a far wider range of temperature during the twenty-four hours than in the former. This agrees with observation. In Sahara, to use the words of Mrs. SOMERVILLE, during "the glare of noon the air quivers with the heat reflected from the red sand, and in the night it is chilled under a clear sky sparkling with its host of stars\*." Were gypsum, however, the prevailing mineral, it is *à priori* certain that this could not be the case to anything like its present extent.

The following experiments furnish some notion of the transmissive power of a few other organic structures: cubes of the substances were examined in the usual manner.

Tooth of Walrus . . . . .	16
Tusk of East Indian Elephant . . . . .	17
Whalebone . . . . .	9
Rhinoceros's-horn . . . . .	9
Cow's-horn . . . . .	9

Considering the density and elasticity of ivory, we might be disposed to attribute to it a comparatively high conductive power; but the experiment proves it to be a very

\* Physical Geography, vol. i. p. 147.

bad conductor—much inferior, indeed, to wood in the direction of the fibre. Doubtless this conduces to the animal's comfort. Exposed to the rays of a tropical sun, if these huge bony masses were capable of assuming a high temperature during the day and losing it again at night, it must be a source of the greatest inconvenience to the animal, as at present constituted. The horns of the Rhinoceros and Cow, however, still more strikingly exemplify that fitness of parts which is perpetually presented to the student of natural science. In the latter case especially, the mass of horn in close contact with the skull, and therefore capable of transmitting heat directly to the animal's brain, must be attended with very unpleasant consequences, if horn were a good conductor. Given such a constitution, the substance fixed upon by our own enlightened intellect to furnish the animal with such weapons of defence, would be just such as nature has chosen.

As a general rule, sudden changes of temperature are prejudicial to animal and vegetable health; the substances used in the construction of organic tissues are exactly such as are best calculated to resist those changes. Coal enters largely into the composition of such tissues, and it is an exceedingly bad conductor. Here are the deflections obtained with three different descriptions of this substance:—

Sunderland coal . . . . .	8°
Boghead cannel . . . . .	8
Lesmahago cannel . . . . .	8

The following results illustrate the subject in a still more striking manner. It is almost needless to remark that each of the substances mentioned was reduced to the cubical form, and submitted to an examination similar in every respect to that of wood and quartz. While, however, a cube of the latter substance produces a deflection of 90°, a cube of

Sealing-wax produces a deflection of . . . . .	0°
Sole leather . . . . .	0
Bees'-wax . . . . .	0
Glue produces a deflection of . . . . .	0°
Gutta-percha . . . . .	0
India-rubber . . . . .	0
Filbert-kernel . . . . .	0
Almond-kernel . . . . .	0
Boiled ham-muscle . . . . .	0
Raw veal-muscle . . . . .	0

The substances here named are all of them animal and vegetable productions; and the experiments demonstrate the extreme imperviousness of every one of them. Starting from the principle that sudden accessions or deprivations of heat are prejudicial to animal and vegetable health, we see that the materials chosen are precisely

those which are best calculated to avert such changes. It is yet to be estimated what influence the extreme non-conductibility of muscular tissue exerts in producing the remarkable constancy of temperature observed in the human body in different climates. The cuticle is an exceedingly bad conductor, and this explains the insensibility to heat of hands on which the skin has been thickened by exposure. Probably many escapes from the fiery ordeal, which have been hitherto referred to collusion, might be scientifically explained by reference to this fact. While studying at Marburg, I have sometimes heard Professor BUNSEN make a good-humoured remark on the tenderness of his pupils' fingers. Accustomed as he was to the manipulation of the glass used in his admirable eudiometrical researches, his fingers had acquired an insensibility to heat sufficient to carry him safely through an ordeal which, in other cases, would undoubtedly invoke the judicial condemnation of the middle ages. The experiments of CHANTREY and BLAGDEN are often referred to as illustrations of the surprisingly high temperature to which the human body may for a short time be exposed without injury. These experimenters owed their safety to two things,—to the non-conductibility of their tissues, and the non-conductibility of the air in contact with them. Were either of these materials changed, the experiments could not have been made. If air were a good conductor, and parted with its heat readily, their hands and faces would have shared the fate of the beefsteak and eggs which were cooked in contact with tin in the same oven. Were their bodies good conductors, they would have become heated like the tin, the heat would have been transferred to the deeper tissues and organs, to the probable destruction of the latter. As it was, however, both the causes mentioned contributed to the success of the experiment, and a mere surface irritation was the only inconvenience felt.